

JOLICO J-B TOOL

PRINTED COPY IS UNCONTROLLED

LOWER AND UPPER BLANKING STEELS

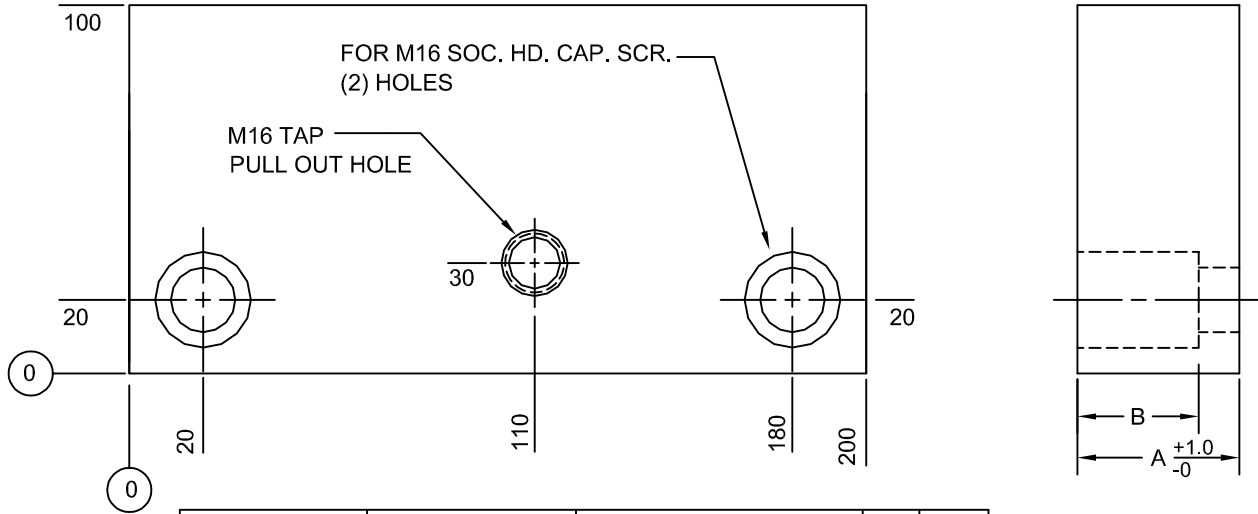

TRIM STEEL	JOLICO NUMBER	FORD PART NUMBER	A	B
LOWER STEEL	J - 226077	WDX3 - 82 - 1235100200	35	19
UPPER STEEL	J - 226078	WDX3 - 82 - 1244100200	44	30

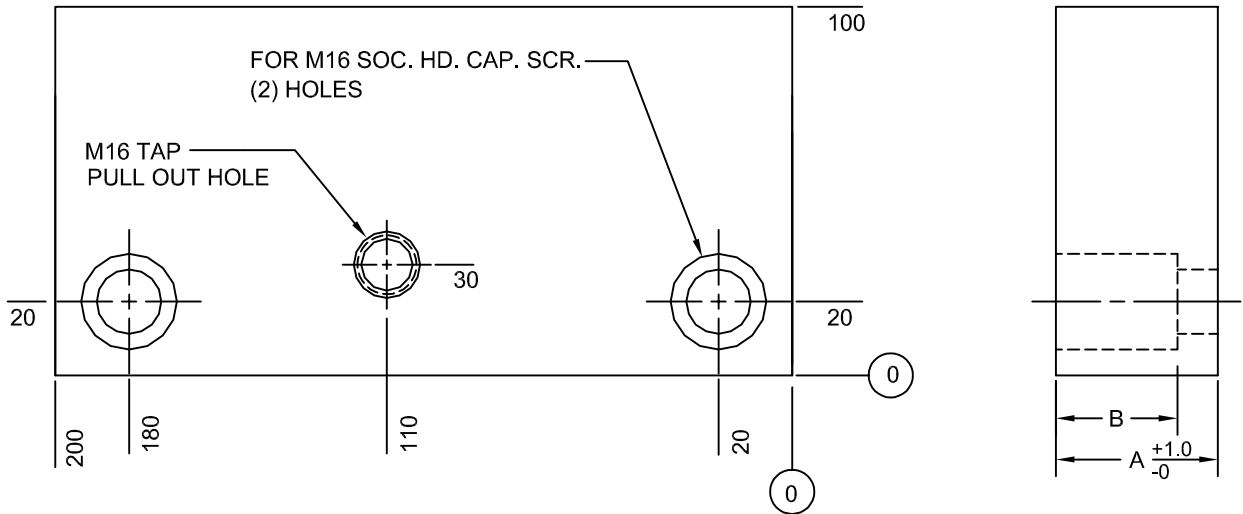

TRIM STEEL	JOLICO NUMBER	FORD PART NUMBER	A	B
LOWER STEEL	J - 226079	WDX3 - 82 - 1335100200	35	19
UPPER STEEL	J - 226080	WDX3 - 82 - 1344100200	44	30

SPECIFY MATERIAL CODE AT END OF ORDERING NUMBER.
 C = 1.7140 / CARMO BAR STOCK FLAME HARDEN Rc 55 MIN.
 D = CALDIE BAR STOCK FLAME HARDEN Rc 60 - 62
 A = AISI - A2 HARDEN Rc 59 - 63
 S = AISI - S7 HARDEN Rc 56 - 58

ORDERING EXAMPLE:

J - 226077 - C

↑
SPECIFY MATERIAL CODE

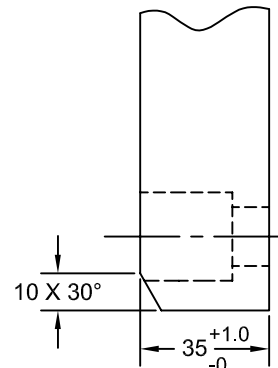

LOWER STEELS ONLY
HAS 10 X 30° CHAMFER