

JOLICO J-B TOOL

PRINTED COPY IS UNCONTROLLED

DIE LIFT PIN WITH SPRING LOADED RETAINER RING AND ROUND LOCK KEY

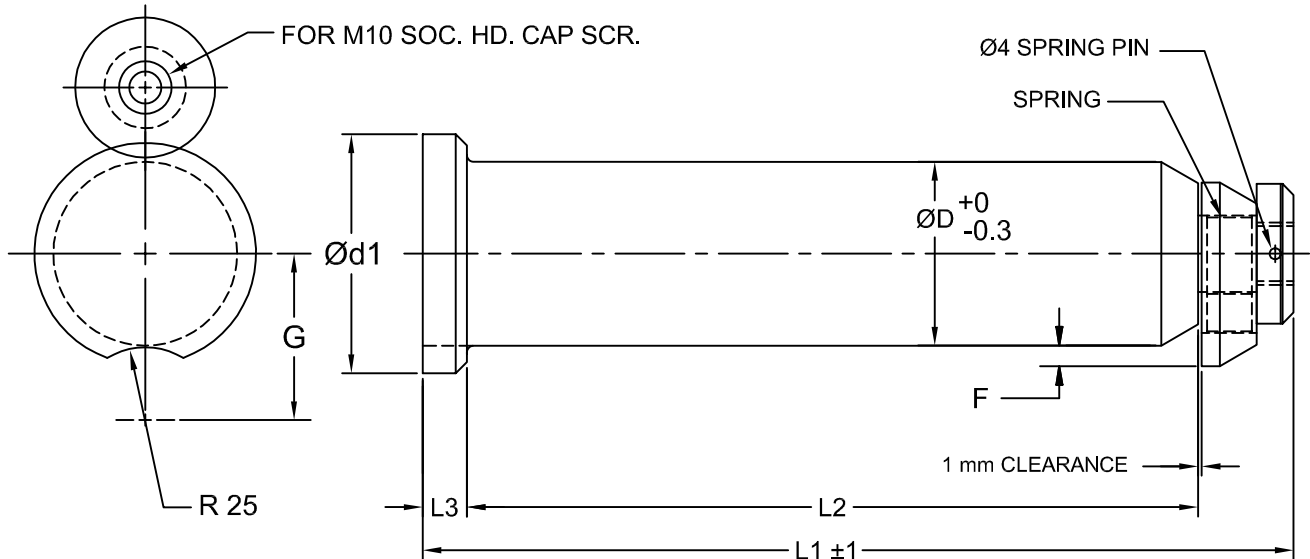

NOTE: ROUND LOCK KEY IS SUPPLIED WITH LIFT PIN

JOLICO NUMBER	FORD PART NUMBER	ØD	Ød1	L1	L2	L3	F	G	TOTAL DIE WEIGHT IN	
									METRIC TONS	U.S. TONS
J-881390	WDX22-80-0663279-A	63	76	320	279	10	9	57	UP TO 44	UP TO 50.1
J-881391	WDX22-80-0680319	80	100	370	319	15	10	69	UP TO 60	UP TO 66

NOTE:
 TOTAL DIE WEIGHT MAXIMUM SAFE DIE HANDLING CAPACITY IS BASED ON A THREE POINT STRAIGHT LIFT, WHICH INCLUDES A TWO POINT SAFE LIFTING CAPACITY FOR DIE TURNOVER.
 THE TOTAL DIE WEIGHT INCLUDES THE TOTAL UPPER AND LOWER DIE WEIGHT TOGETHER BASED ON THAT ALL UPPER AND LOWER DIE LIFT PINS ARE THE SAME SIZE ON THE DIE.

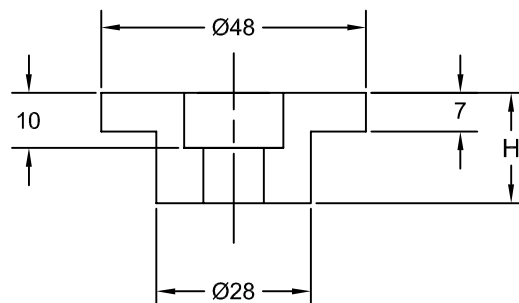
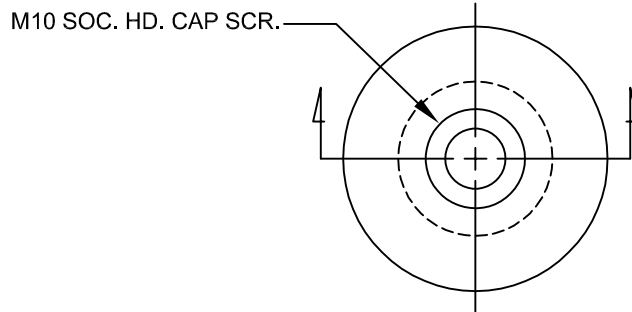

ROUND LOCK KEY

JOLICO NUMBER	H	PIN DIA.
J-881390-2	20	63
J-881391-2	25	80