

BRONZE CAM WEAR PLATES 50 mm WIDE GM TYPE "A" AND "B" CAM WEAR PLATE

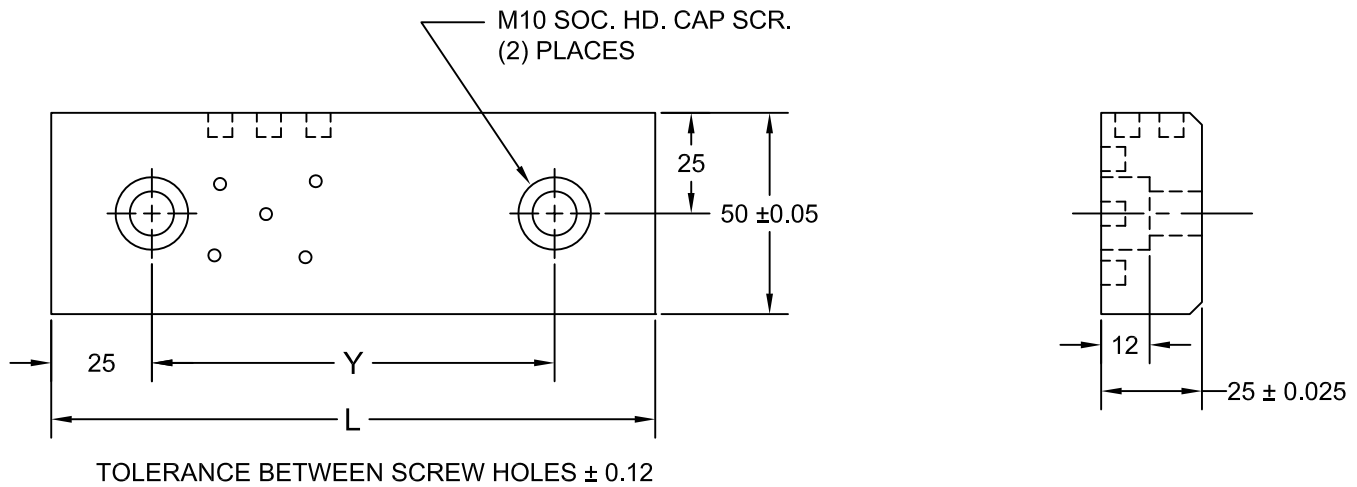

CAME WEAR PLATE TYPE "A"

JOLICO NUMBER	GMGDS CODE NUMBER	L LENGTH	Y
J - 777530	90.75.70 - A150	150	100
J - 777531	90.75.70 - A200	200	150

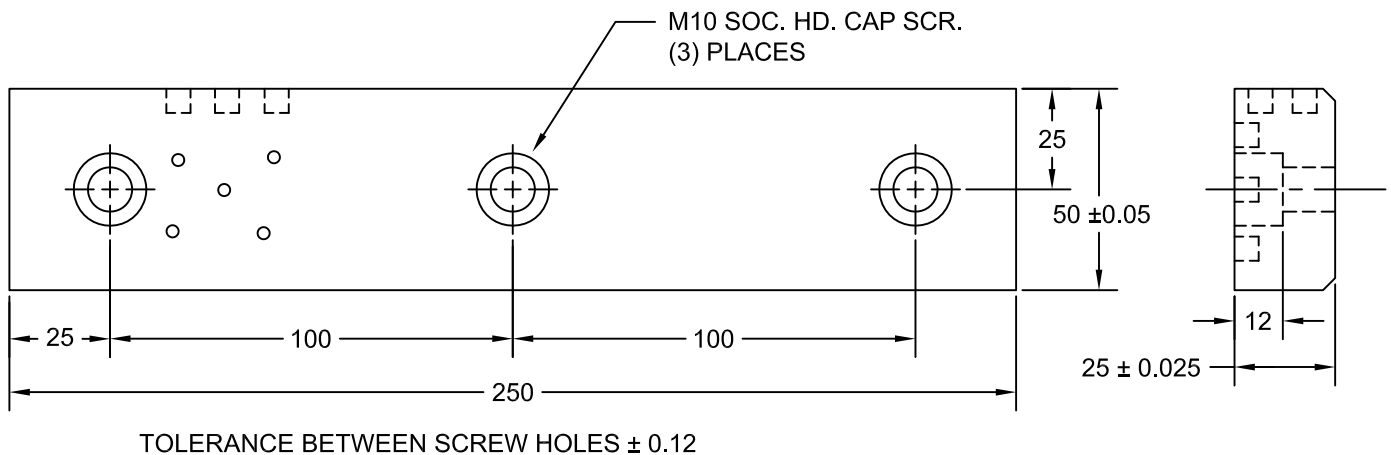

CAME WEAR PLATE TYPE "B"

JOLICO NUMBER	GMGDS CODE NUMBER
J - 777532	90.75.70 - B250