

JOLICO J-B TOOL

PRINTED COPY IS UNCONTROLLED

BRONZE CAM WEAR PLATES 75 WIDE GM TYPE "C" AND "D" CAM WEAR PLATE

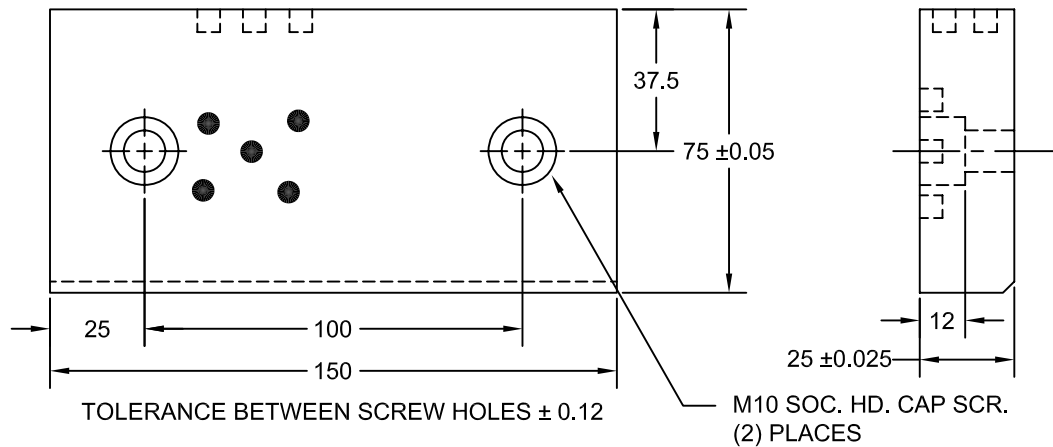

CAM WEAR PLATE TYPE "C"

JOLICO NUMBER	GMGDS CODE NUMBER
J - 777533	90.75.70 - C150

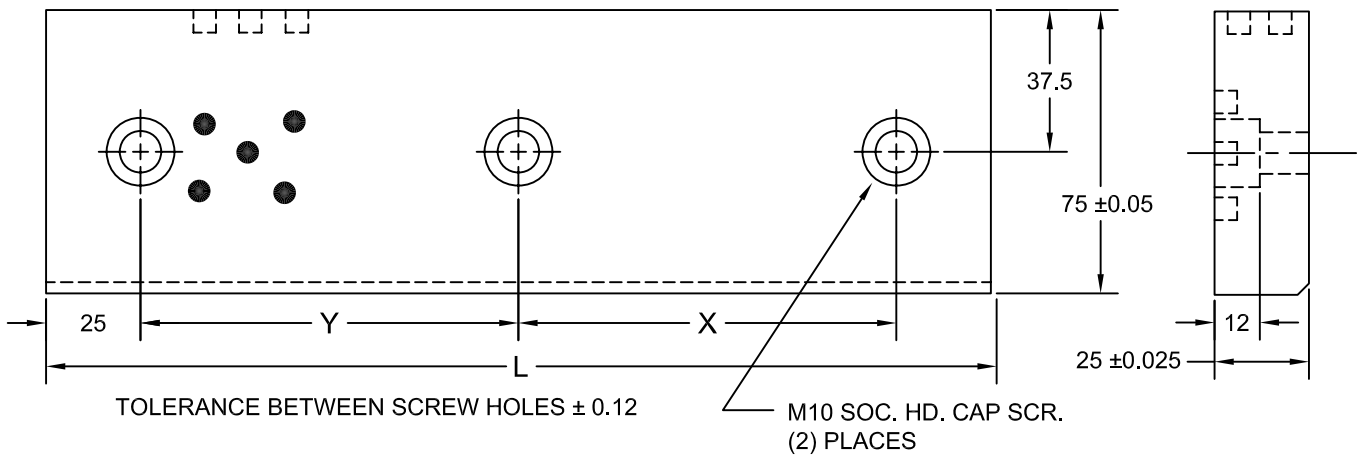

CAM WEAR PLATE TYPE "D"

JOLICO NUMBER	GMGDS CODE NUMBER	L LENGTH	Y	X
J - 777534	90.75.70 - D200	200	75	75
J - 777535	90.75.70 - D250	250	100	100