

PRINTED COPY IS UNCONTROLLED

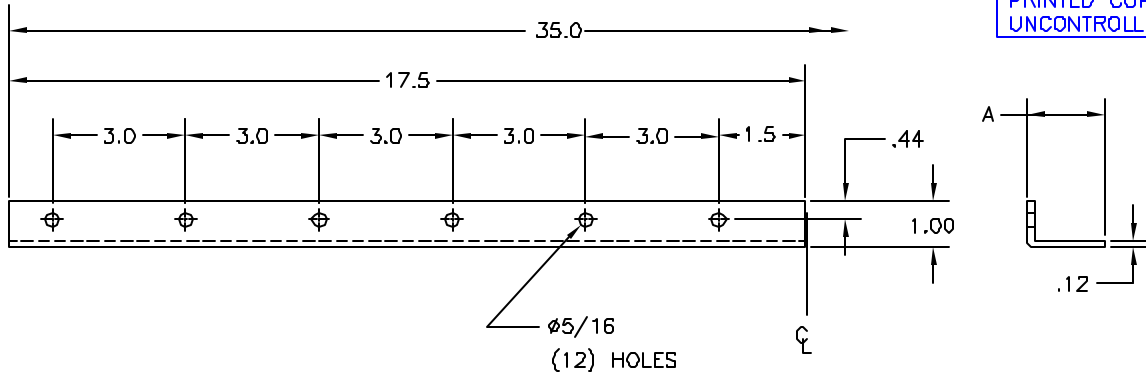

SHEET METAL GUARDS

THIS DETAIL IS PRIMARILY USED ON SMALL DIES TO GUARD SPRING PADS.

JOLICO NO.	REF. NO.	A
J-36301	DX14-8-0301	1.75
J-36302	DX14-8-0302	2.25

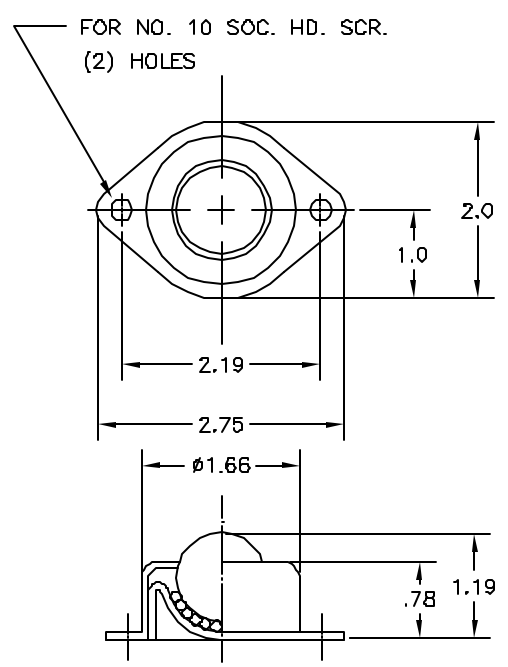

BALL TYPE STOCK TRANSFER

FOR USE ON LOWER SHEDDING ANGLE CHUTES, OR FOR FEEDING STOCK INTO DIE

JOLICO NO.	REF. NO.
J-87201	DX18-28-0201
J-87201-N	

NYLON

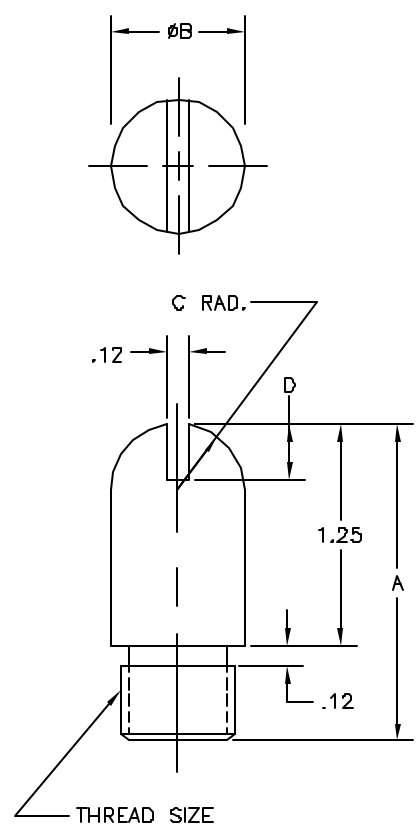

SPRING STUDS

PERMITS RETENTION OF DIE SPRING WITHOUT BORING INTO PAD OR SHOE

JOLICO NO.	REF. NO.	A	B	C	D	THREAD SIZE
J-96394	0695394	1.75	0.75	.38	.31	5/8-11
J-96472	0695472	2.06	1.00	.50	.44	3/4-10