

# ROLLER STOCK GUIDES

PRINTED COPY IS UNCONTROLLED

THIS DETAIL IS A STATIONARY ROLLER THAT GUIDES STOCK INTO THE DIE.

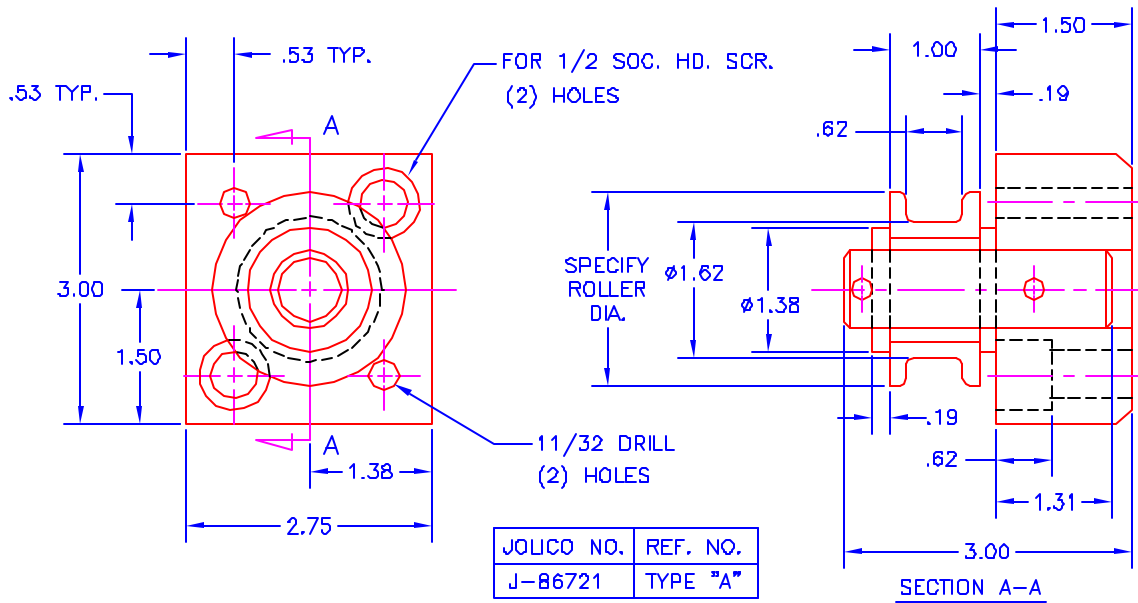

NOTE:  
2" DIA. ROLLER FOR STOCK UP TO 12" WIDE  
3" DIA. ROLLER FOR STOCK OVER 12" WIDE

THIS DETAIL IS A STATIONARY ROLLER THAT CAN MOVE UP AND DOWN TO FOLLOW THE UP AND DOWN MOVEMENT OF THE STOCK IN A COMPOUND BLANK AND PIERCE DIE.

