

# FLANGE STRIPPER

PRINTED COPY IS UNCONTROLLED

THESE GAGES ARE USED ON HOOD AND PANEL DIES FOR FLANGE STRIPPERS, LOCATING AND POSITIONING.

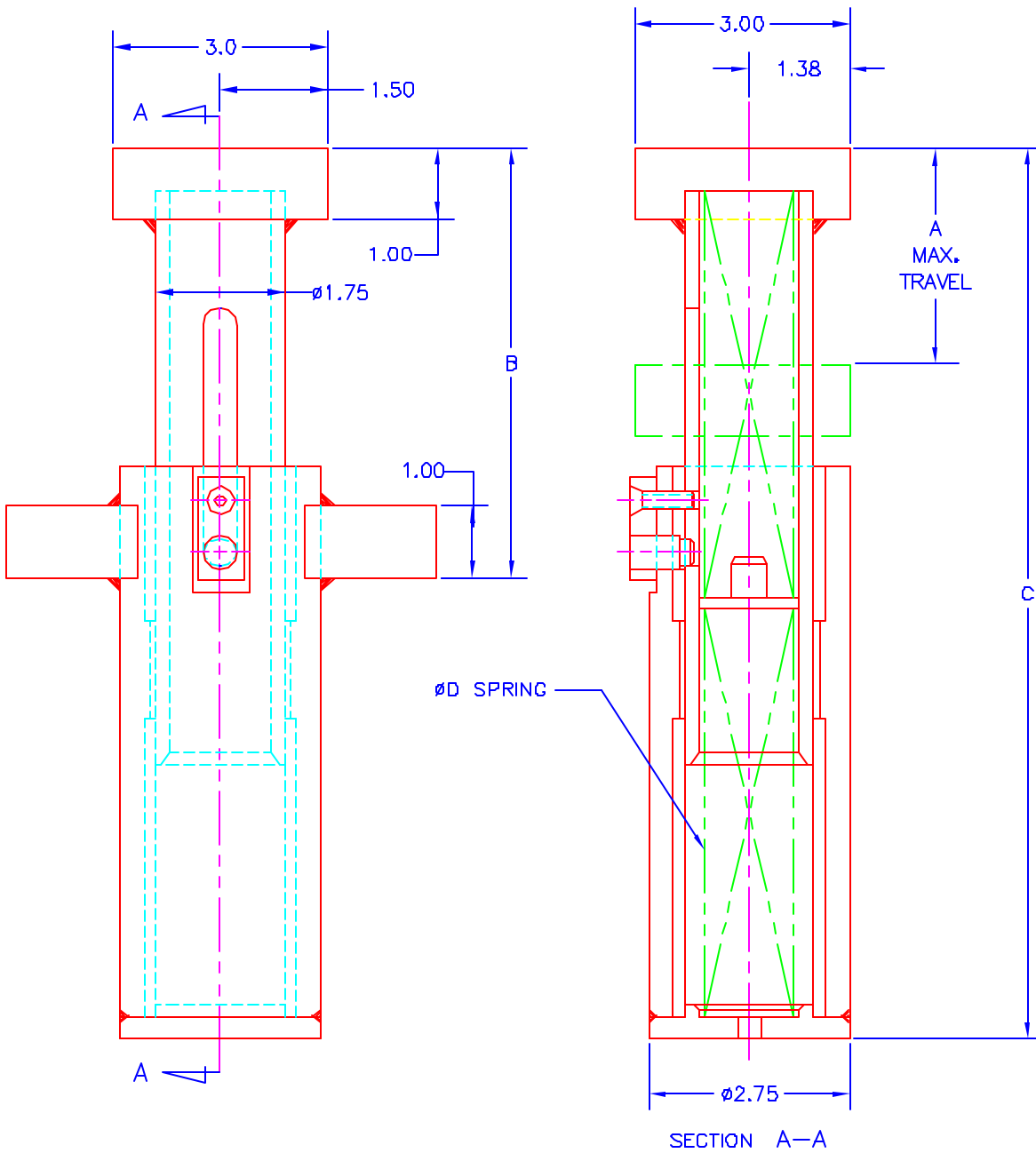

JOLICO NO.	REF. NO.	A	B	C	(D) MED. HIGH PRESSURE SPRING
J-40800		SPECIFY TRAVEL LENGTHS OVER 4.0 INCHES			
J-40801	M-3961-A	2.0	5.25	8.75	1 REQ'D. 1-1/4 O.D. X 8.0 F.L.
J-40802	M-3961-B	2.5	5.75	10.75	1 REQ'D. 1-1/4 O.D. X 10.0 F.L.
J-40803	M-3961-C	3.0	6.25	12.75	1 REQ'D. 1-1/4 O.D. X 12.0 F.L.
J-40804	M-3961-D	3.5	6.75	14.75	2 REQ'D. 1-1/4 O.D. X 7.0 F.L.
J-40805	M-3961-E	4.0	7.25	14.75	2 REQ'D. 1-1/4 O.D. X 7.0 F.L.