

# INDIRECT LIFTER SHAFT SUPPORT

PRINTED COPY IS UNCONTROLLED

LIFTER SHAFT SUPPORTS CONTAIN AND GUIDE LIFTER PINS LIKE SHOWN ON PAGE JH-22

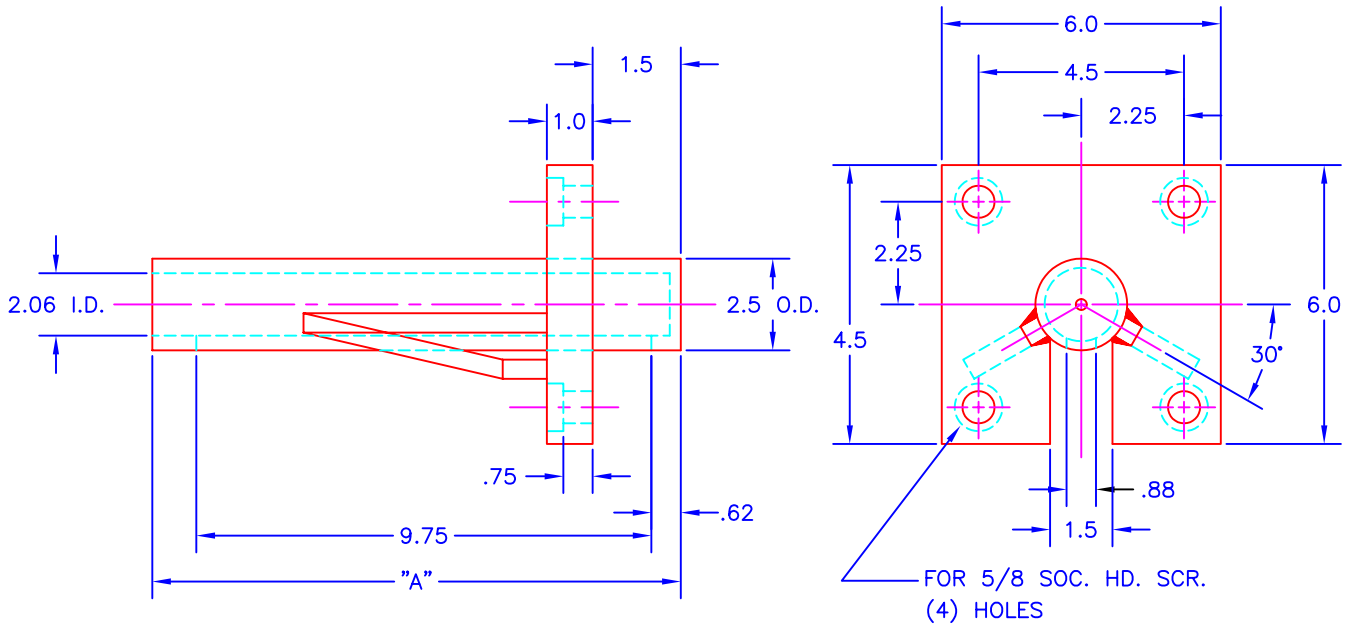

JOLICO NO.	REF. NO.	A
J-53102	DX18-10-0701	11.5
J-53103	DX18-10-0702	*

\* IF HEIGHT GREATER THAN 11.5 IS REQUIRED ORDER BY ADDING "A" DIMENSION.  
EXAMPLE: J-53103 X A=13.5 LG.

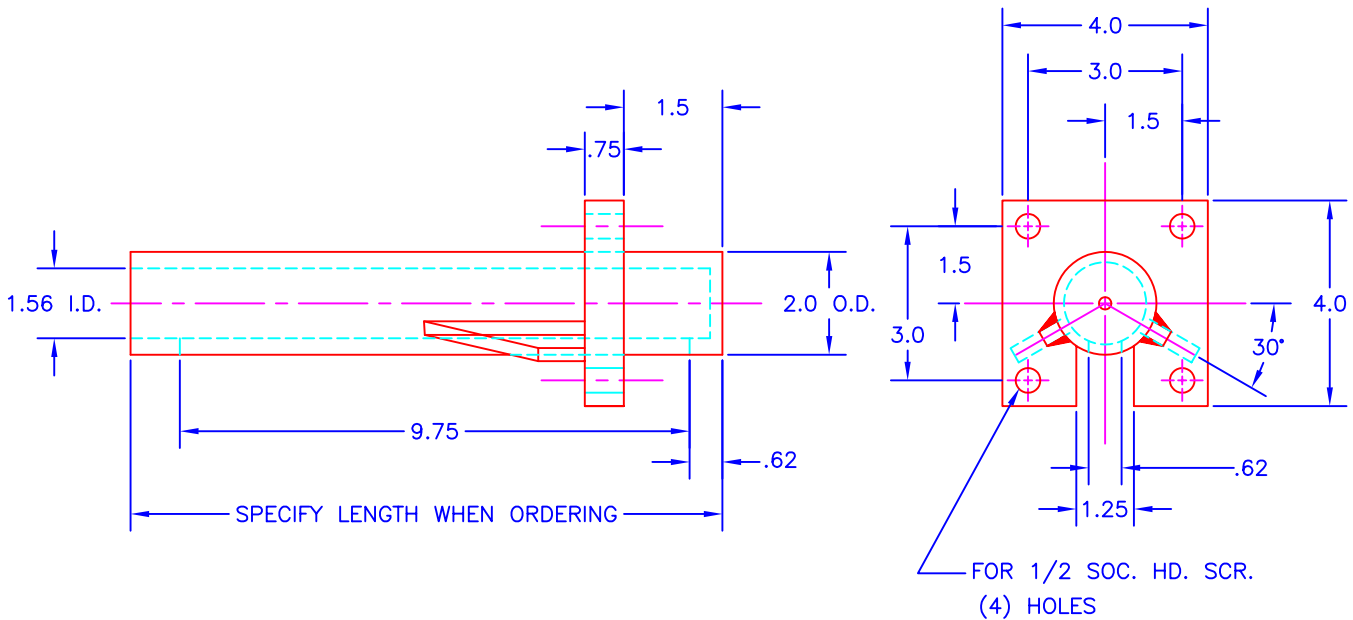

JOLICO NUMBER  
J-53104 X LENGTH