

AUTOMATION COLLARS

THESE DETAILS ARE USED TO RETAIN AUTOMATION SHAFTING.
ONE COLLAR AT EACH END OF THE SHAFT, NEXT TO A
PILLOW BLOCK WILL RETAIN THE SHAFTING

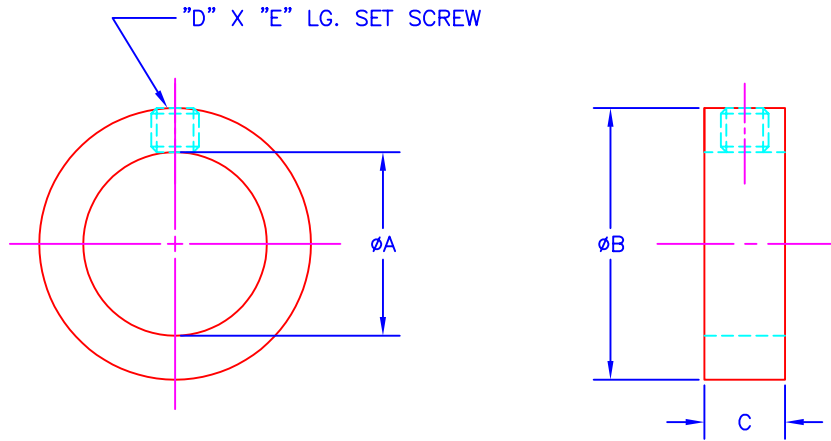

JOLICO NO.	OLD "J" NO.	REF. NO.	REF. NO.	A	B	C	D	E
J-55501	J-55405	DX18-28-1405	AC-28	2.00	3.00	.88	1/2-13	.50
J-55502				1.47	2.25	.75	3/8-16	.38

PILLOW BLOCKS

THESE SELF LUBRICATION PILLOW BLOCKS ACT
AS A BUSHING FOR AUTOMATION SHAFTING.

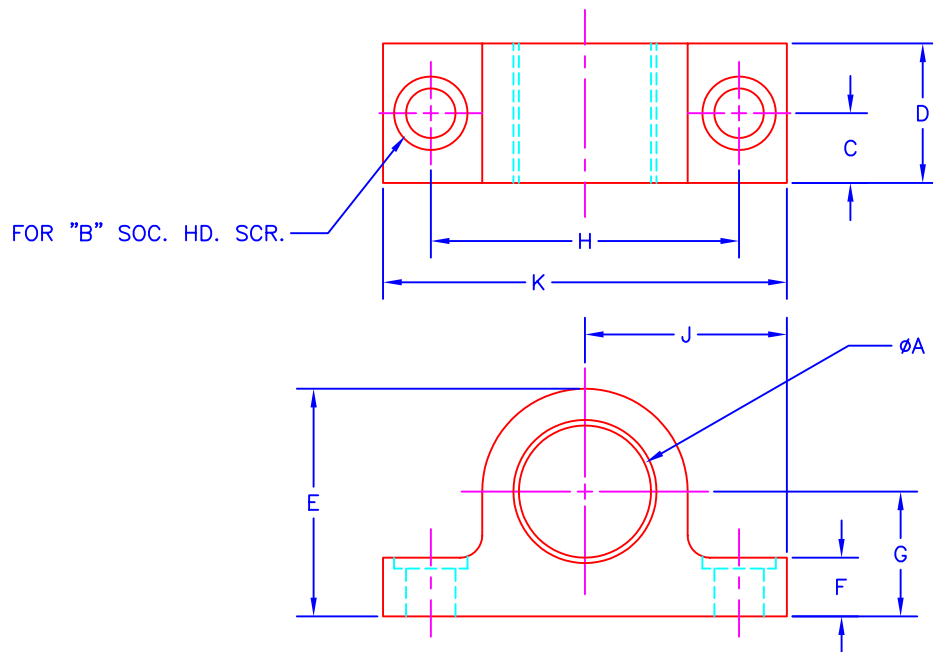

JOLICO NO.	A	B	C	D	E	F	G	H	J	K
J-55301	1.972/1.975	5/8	1.00	2.00	3.25	.75	1.880/1.882	5.50	3.50	7.00
J-55302	1.972/1.975	5/8	1.00	2.00	3.12	.50	1.748/1.750	4.38	2.81	5.62
J-55303	1.435/1/439	1/2	.75	1.50	2.50	.62	1.373/1.375	3.50	2.25	4.50