

STOP BLOCKS

PRINTED COPY IS UNCONTROLLED

STOP BLOCKS ARE USED TO SET THE PROPER SHUT HEIGHT AT DIE SET UP.

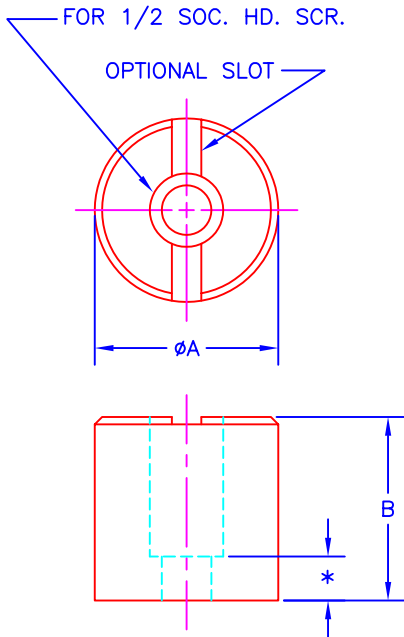

* .5 WHEN STOP BLOCK IS LESS THAN 2.5 IN HEIGHT AND 1.25 WHEN 2.5 OR HIGHER.

ALL STOP BLOCKS ARE PLUS 1/16 IN HEIGHT FOR FITTING

(OPTIONAL SLOT) WHEN ORDERING ADD "S" TO CATALOG NUMBER

NOTE:

WILL QUOTE AND MANUFACTURE ANY SPECIALS UPON CUSTOMER REQUEST.

REF. NO. DX13-10-1003 X LG.		
JOLICO NO.	A	B
J-28011	2.00	1.25
J-28012	2.00	1.50
J-28013	2.00	1.75
J-28020	2.00	2.00
J-28021	2.00	2.25
J-28022	2.00	2.50
J-28023	2.00	2.75
J-28030	2.00	3.00
J-28031	2.00	3.25
J-28032	2.00	3.50
J-28033	2.00	3.75
J-28040	2.00	4.00
J-28041	2.00	4.25
J-28042	2.00	4.50
J-28043	2.00	4.75
J-28050	2.00	5.00
J-28051	2.00	5.25
J-28052	2.00	5.50
J-28053	2.00	5.75
J-28060	2.00	6.00
J-28061	2.00	6.25
J-28062	2.00	6.50

REF. NO. DX13-10-1004 X LG.		
JOLICO NO.	A	B
J-28111	2.50	1.25
J-28112	2.50	1.50
J-28113	2.50	1.75
J-28120	2.50	2.00
J-28121	2.50	2.25
J-28122	2.50	2.50
J-28123	2.50	2.75
J-28130	2.50	3.00
J-28131	2.50	3.25
J-28132	2.50	3.50
J-28133	2.50	3.75
J-28140	2.50	4.00
J-28141	2.50	4.25
J-28142	2.50	4.50
J-28143	2.50	4.75
J-28150	2.50	5.00
J-28151	2.50	5.25
J-28152	2.50	5.50
J-28153	2.50	5.75
J-28160	2.50	6.00
J-28161	2.50	6.25
J-28162	2.50	6.50

JOLICO NO.	A
J-28513	1.75
J-28520	2.00
J-28521	2.25
J-28522	2.50
J-28523	2.75
J-28530	3.00
J-28531	3.25
J-28532	3.50
J-28533	3.75
J-28540	4.00
J-28541	4.25
J-28542	4.50
J-28543	4.75
J-28550	5.00
J-28551	5.25
J-28552	5.50
J-28553	5.75
J-28560	6.00

