

# CAM RETURN AND SAFETY STUDS

PRINTED COPY IS UNCONTROLLED

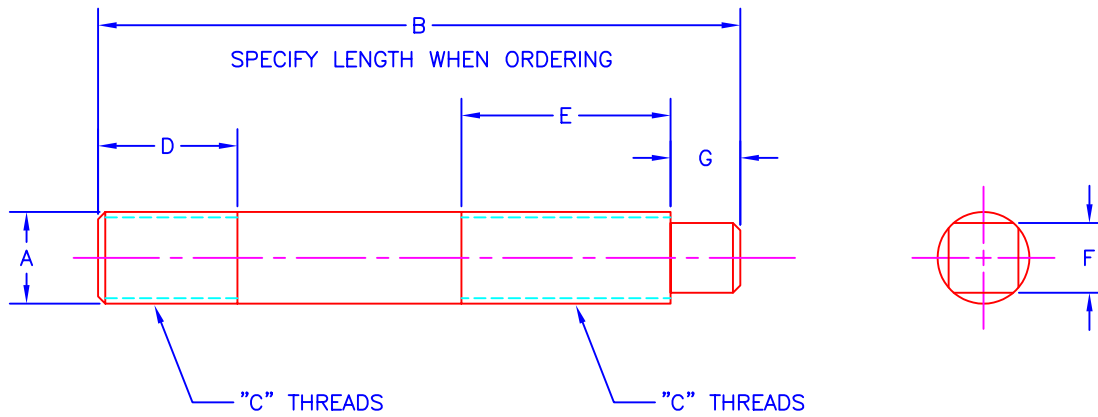

ORDERING EXAMPLE  
J-20128-B14.50-D1.12-E3.00

JOLICO NO.	A	B	C	D	E	F	G	REFERENCE
J-20126	.50	12.00 TO 22.00 ORDER IN .50 INCREMENTS	1/2-13	.75 OR 1.25	1.50 OR 2.00	.32	.50	CHEVY REQ.
J-20127	.62		5/8-11	.93 OR 1.50	1.75 OR 2.50	.38	.50	
J-20128	.75		3/4-10	1.12 OR 1.75	2.00 OR 3.00	.50	.62	
J-20129	1.00		1" - 8	1.50 OR 2.25	2.50 OR 4.00	.75	.75	

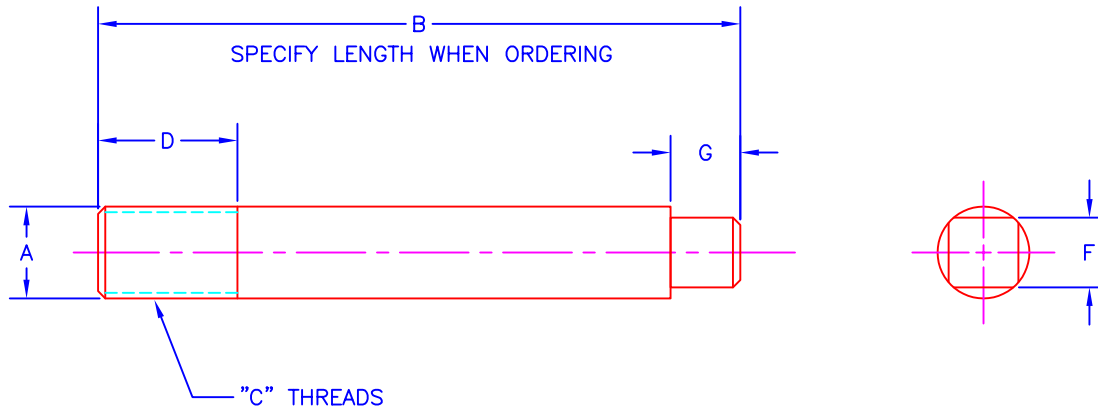

ORDERING EXAMPLE  
J-20132-B5.50-D1.12

JOLICO NO.	A	B	C	D	F	G	REFERENCE
J-20130	.50	4.00 TO 14.00 ORDER IN .50 INCREMENTS	1/2-13	.75 OR 1.25	.32	.50	CHEVY REQ.
J-20131	.62		5/8-11	.93 OR 1.50	.38	.50	
J-20132	.75		3/4-10	1.12 OR 1.75	.50	.62	
J-20133	1.00		1" - 8	1.50 OR 2.25	.75	.75	