

# FLOW TRACK ASSEMBLIES

PRINTED COPY IS UNCONTROLLED

THESE FLOW TRACK ASSEMBLIES ARE USED FOR SHEDDING PARTS WHEN THE PROPER SHEDDING ANGLE CANNOT BE MAINTAINED.

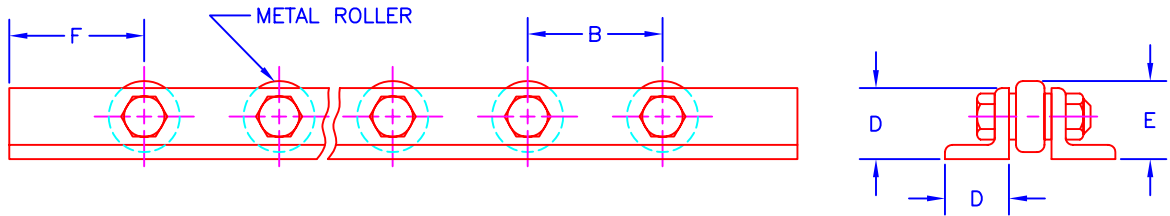
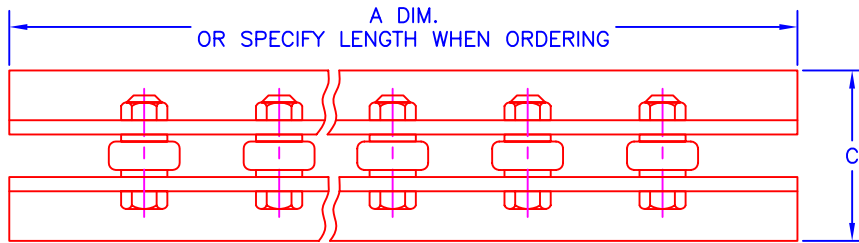

JOLICO NO.	REF. NO.	A	B	C	D	E	F
J-32315	20-175-0300	60.0	1.50	1.88	.75	.88	.75
J-32320	20-175-0305	120.0	1.50	1.88	.75	.88	.75
J-32325	_____	60.0	3.00	1.88	.75	.88	1.50
J-32330	_____	120.0	3.00	1.88	.75	.88	1.50
J-32335	_____	60.0	1.50	2.62	1.12	1.28	.75
J-32340	_____	120.0	1.50	2.62	1.12	1.28	.75
J-32345	_____	60.0	3.00	2.62	1.12	1.28	1.50
J-32350	_____	120.0	3.00	2.62	1.12	1.28	1.50

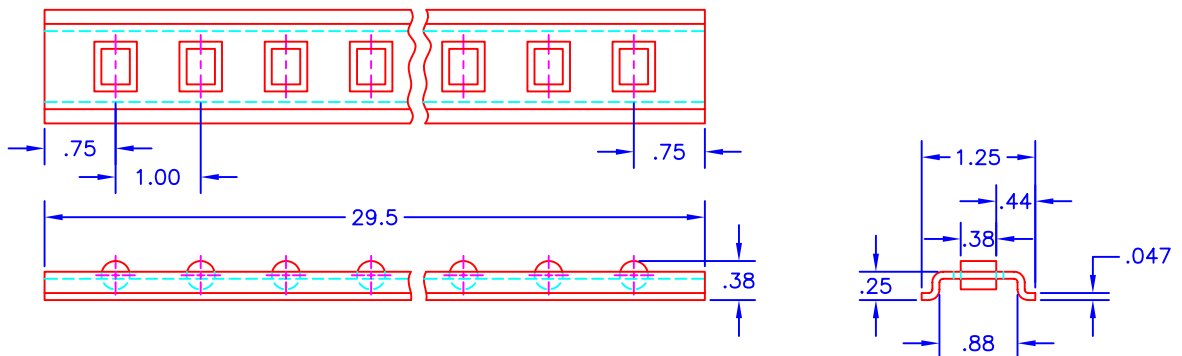

JOLICO NO.	REF. NO.	ROLLER TYPE
J-32110	FTS-11-H	STEEL